

## UHMW-PE drag flights and paddles

UHMW-PE drag flights and paddles offer an abrasion resistant, non-stick option for efficiently conveying bulk materials. The low coefficient of friction surface of UHMW-PE ensures material release at the end of the conveyor, minimizing carry-back and down time due to material build-up.

To fit different popular drag conveyor designs, we can custom make flights based on your drawing or sample, using our CAD based software and manufacturing process

### Size(inch)

Length	6	9	10	12	14	16	18	20	24
Thickness	1/4	1/4	/	/	/	/	/	/	/
	3/8	3/8	3/8	3/8	3/8	3/8	3/8	/	/
	/	1/2	1/2	1/2	1/2	1/2	1/2	1/2	1/2
	/	/	/	/	/	/	/	5/8	5/8

### Specifications

**MATERIAL:** Virgin Ultra High Molecular Weight (UHMW) polyethylene is white. Reprocessed UHMW polyethylene is black. Static reduced UHMW is black. UHMW has a thickness tolerance of +/- 10%.

**STYLE:** Drag conveyor flights are fabricated to original manufacturer's design. Cut edges are square unless otherwise noted.

**CUSTOM FLIGHTS:** Non-standard flights can be custom fabricated to your specifications. Please send print or sample for fabrication of flight.

**TEMPERATURE:** -22° F to +180° F or -51° C to +82° C

**ORDERING:** Before ordering, please note manufacturer design, number of flights, size and thickness. If a custom drag conveyor flight is required, please have sample or drawing available.



SCREW CONVEYOR SUPERFLO



ESSMUELLER COMPANY PEERLESS



THOMAS CONVEYOR FLI-CON



JEFFERY MULTI-FLOW



EHRSAM DRACON

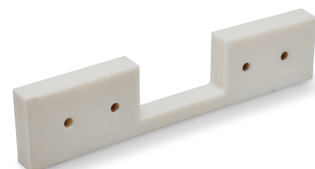

ENMASSE

## Flat-Bottom flights(BF)

The flat-bottom flight is the most customized flight design. Please fill in the following dimensions.

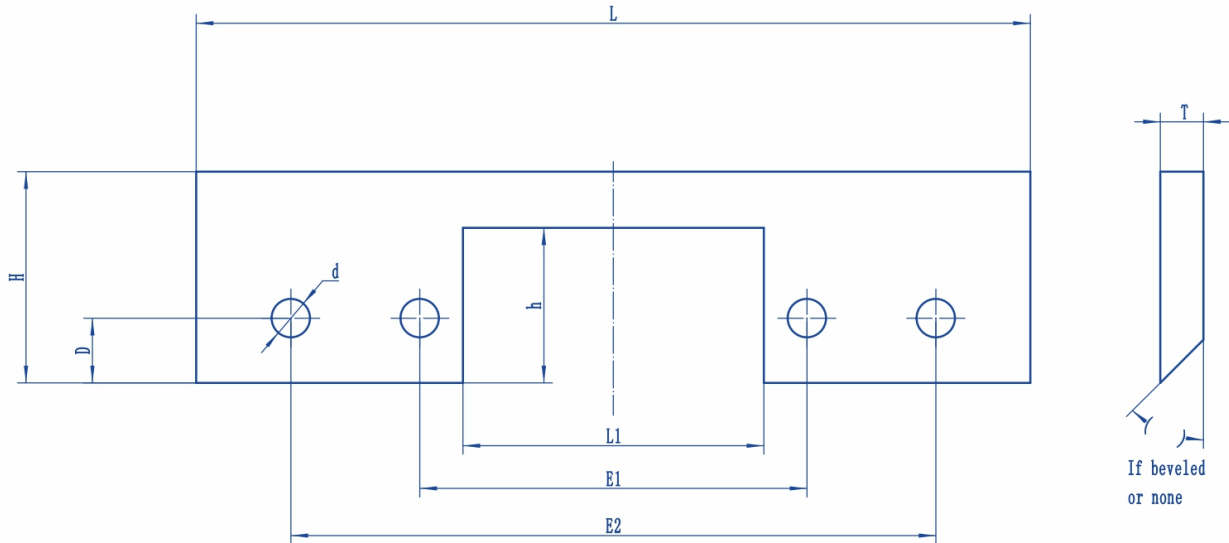

### UHMW-PE

Model. No.	L	L1	T	H	h	E1	E2	D	d
BF154×60×8	154	56	8	60	47	100	/	30	9
BF194×60×8	194	56	8	60	47	120	/	30	9
BF240×70×8	240	70	8	70	56	104	194	35	9
BF235×53×10	235	80	10	53	43	110	200	23	9
BF235×57.5×10	235	62	10	57.5	45.5	105	185	22.5	9
BF300×73×10	300	65	10	73	60.5	141	231	30	9
BF305×53×10	305	80	10	53	43	110	200	23	9
BF310×70×12	310	90	12	70	56	115	245	35	9
BF340×67×8-12	340	90	8-12	67	53	135	275	32	9

### NYLON/ UHMW-PE

Model. No.	L	L1	T	H	h	E1	E2	D	d
BF180*92*12	180	58	12	92	43	120	/	26	9
BF230*108*12	230	70	12	108	50	104	194	28	9
BF300*108*12	300	70	12	108	50	115	245	28	9
BF312*82*14	312	74	14	82	62	120	240	30	9
BF330*108*12	330	70	12	108	50	135	275	28	9
BF300*38*10	300	54	10	38	29	85	165	14.5	6.5

## HDPE/UHMW-PE

Model. No.	L	L1	T	H	h	E1	E2	D	d
BF145*45	145	75	14	45	36	102	/	19	9
BF184*45	184	75	14	45	36	102	/	19	9
BF185*50	185	90	14	50	35	115	/	15	9
BF194*49	194	70	14	49	36	90	150	16	9
BF208*49	208	70	14	49	36	90	150	17	10
BF240*49	240	72	14	49	37	95	195	19	9
BF240*49M	240	72	14	49	37	104	195	19	9
BF255*49	255	70	14	49	35	105	190	16	9
BF284*45	284	75	14	45	36	102	228	19	9
BF305*45	305	75	14	45	36	102	228	19	9
BF305*50	305	90	14	50	38	115	245	18	9
BF305*55	305	70	14	55	38	95	195	22	9
BF305*55ZC	305	70	14	55	42.5	102	228	22	9
BF310*50	310	70	10	50	40	148	236	20	10
BF350*70	350	50	14	70	52	/	/	/	/
BF360*45	360	75	14	45	36	102	228	19	9
BF380*60	380	70	16	60	45	155	255	25	9
BF380*60B	380	70	16	60	45	102	228	25	9
BF385*52	385	75	14	52	38	190	320	20	9
BF380*90	380	90	15	90	70	155	255-265	44	9
BF480*90	480	90	16	90	70	170	310	44	9

## Round flights

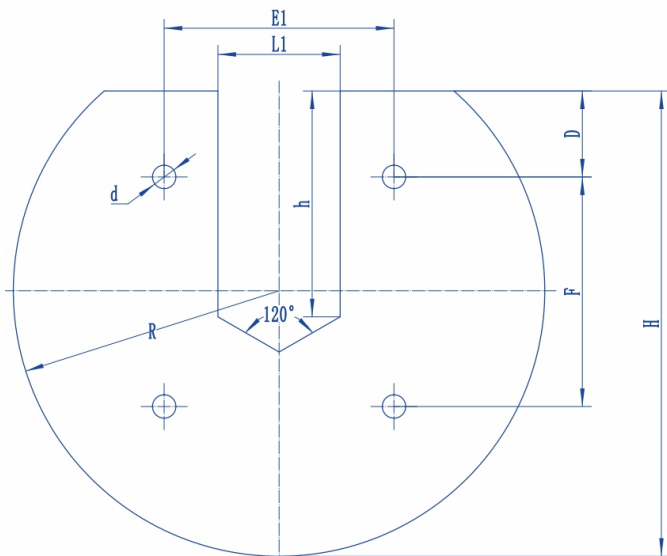

## NYLON/HDPE/UHMW-PE

Model. No.	BBD184	BBD235	BBD284
L1	54	54	54
T	12.7	12.7	12.7
H	165	206	276
h	84.4	100	144.5
R	92	117.5	143
E1	90	101.6	114
F	/	101.6	127
D	67	38.1	70
d	10.5	10.5	10.5

## Round-Bottom flights(BR)

Round bottom flights are standardized according to conveyor manufacturer. Please fill in the following dimensions.

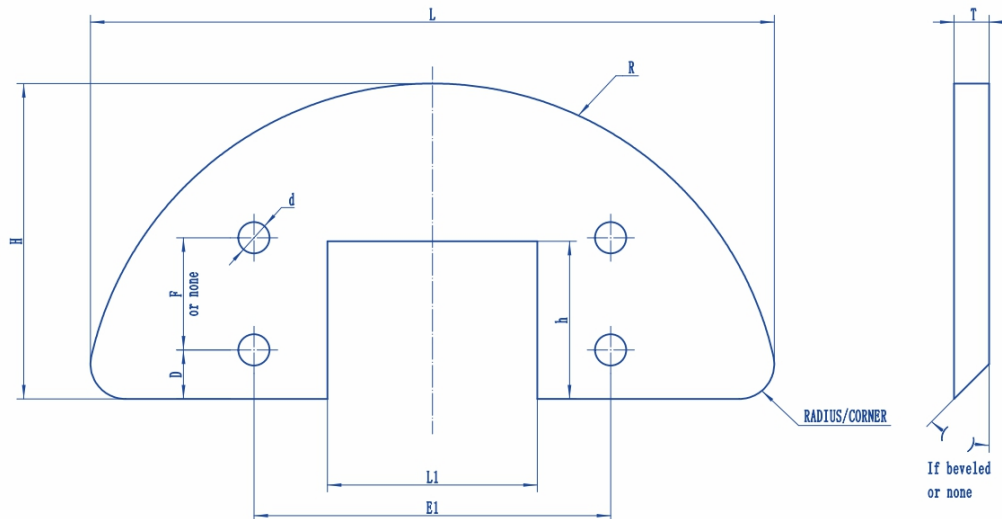

## HDPE/UHMW-PE

Model. No.	L	L1	T	H	h	R	E1	F	D	d
BR80×58	150	50	10	58	30	80	80	/	16	7
BR80×70	160	52	10	70	46	80	74	27	12	7
BR90×90	180	60	10	90	48	90	102	32	14	9
BR100×74	190	55	10	74	43	100	102	32	12	9
BR100×90	196	60	10	90	49	100	102	32	15	9
BR110×70	195	48	10	70	40	110	/	/	11	9
BR110×77	200	40	9	77	42	110	50	/	53	9
BR122×90	230	60	10	90	40	122	102	32	14	9
BR125×100	242	60	10	100	50	125	102	32	17	9
BR135×110	262	72	10	110	53	135	102	32	19	9
BR155×110	295	80	14	110	55	155	120	32	20	9
BR158×110	300	60	144	110	55	158	102	32	21	9
BR158×132	300	50	14	132	50	158	111.6	32	16	10
BR162×108	303	104	14	108	67	162	/	/	/	9
BR185×132	350	60	14	132	58	185	102	32	19	9
BR198×148	375	60	14	148	77	198	142	32	26	9
BR205×142	390	60	15	142	56	205	102	32	18	9
BR80×64×10C	148	50	10	64	38	80	83	/	20	7
BR100×84×10C	188	50	10	84	50	100	102	32	18	9
BR122×90×10C	230	60	10	90	50	122	102	32	14	9
BR125×109×10C	240	60	10	109	55	125	102	32	18	9
BR158×110×12C	294	60	12	110	60	158	102	32	21	9

## NYLON/ UHMW-PE

Model. No.	L	L1	T	H	h	R	E1	F	D	d
BR84×60	156	35	12.7	60	39	84	64.5	/	29	9
BR121×100	235	54	12.7	100	65	121	61.5	/	75	10.5
BR159×135	311	67	12.7	135	99	159	108	28.5	61	10.5
BR184×162	364	67	12.7	162	119	184	108	28.5	78	10.5
BR210×187	415	67	12.7	187	136	210	108	54	136	10.5
BR235×210	485	2-67	12.7	210	132	235	143-114	54	106	10.5

## Guide rails

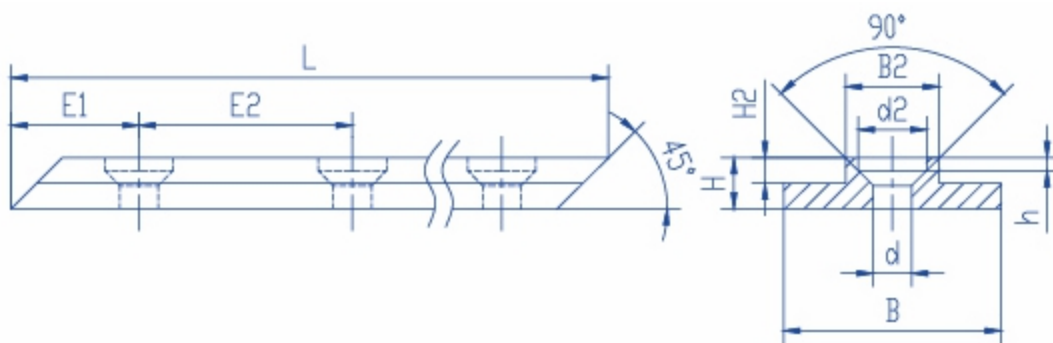

L	B	H	B2	H2	h	d	d2	E1	E2
2000	51	12	22	6	3	9	16	50	100
L×B×H can be customized									